

SECTION 6**ENGINE****CONTENTS**

<u>SUBJECT</u>	<u>PAGE</u>
Engine.....	6A
Isuzu Engine.....	6A6
Cooling System.....	6B1
Radiator	6B2
Fan	6B3
Fuel System.....	6C1
Diesel Fuel Injection	6C3
Engine Electrical.....	6D
Exhaust.....	6F

SECTION 6A**ENGINE**

NOTICE: When fasteners are removed, always reinstall them at the same location from which they were removed. If a fastener needs to be replaced, use the correct part number fastener for that application. If the correct part number fastener is not available, a fastener of equal size and strength (or stronger) may be used. Fasteners that are not reused, and those requiring thread locking compound will be called out. The correct torque value must be used when installing fasteners that require it. If the above conditions are not followed, parts or system damage could result.

CONTENTS

<u>SUBJECT</u>	<u>PAGE</u>
Engine Replacement.....	6A- 2
Engine Mountings.....	6A- 7
Description	6A- 7
Maintenance	6A- 7
Front Engine Mount Replacement.....	6A- 7
Rear Engine Mount Replacement	6A- 8
Exhaust Brake System	6A- 8
Description	6A- 8
Operation	6A- 8
Diagnosis of Exhaust Brake	6A-11
Exhaust Brake On-Vehicle Service	6A-12
Component Locations	6A-12
Magnetic Valve Replacement.....	6A-12
Vacuum Chamber Replacement.....	6A-12
Exhaust Brake Valve Replacement	6A-12
Accelerator Switch Replacement	6A-13

Clutch Switch Replacement.....	6A-14
Specifications.....	6A-15
Fastener Torques.....	6A-15

ENGINE REPLACEMENT

Remove or Disconnect (Figures 1-13)

1. Battery negative cable (1) at the battery (figure 1).
Main feed wire (5) at the starter solenoid (figure 2).
2. Cooling system drain valve on the bottom rear of the radiator.
3. Engine oil at the oil pan plug.
4. Heater hoses at the water pump and thermostat housing. Refer to COOLING SYSTEM (SEC. 6B1) in this manual.
5. Air conditioning condenser mounts. Do not disconnect the hoses from the condenser. Secure the condenser forward of the radiator.
6. Air intake pipe (6) with connecting hose (7) from the turbocharger and the air cleaner (figure 3).

Important

- Tape the inlet opening of the turbocharger to prevent entry of foreign material.

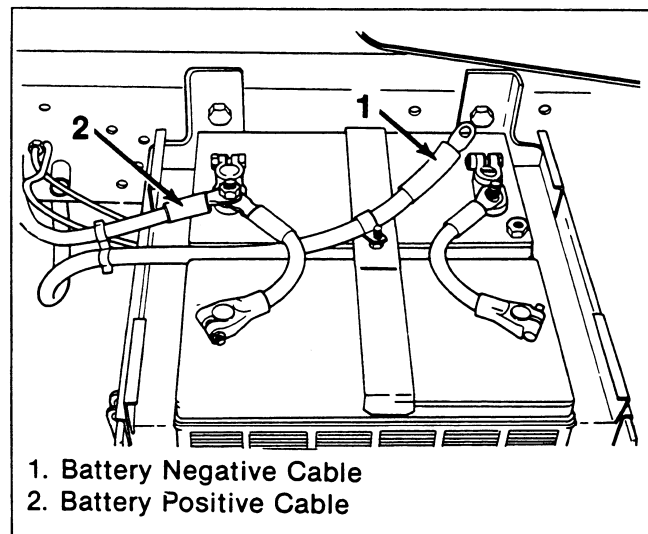

Figure 1. Battery Cable Identification

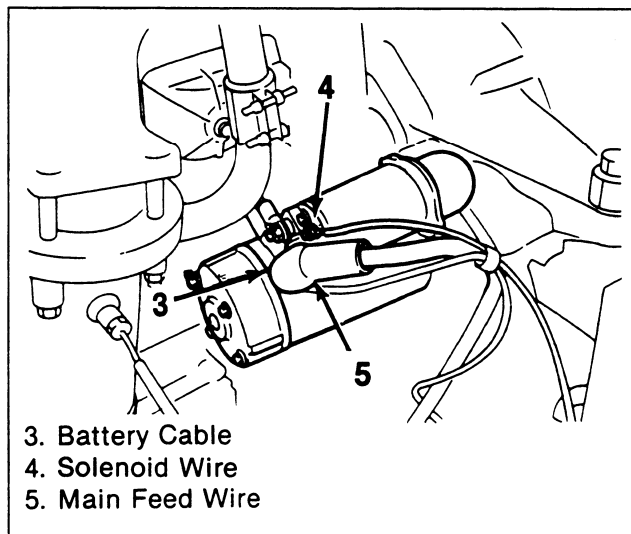

Figure 2. Wiring at Starter

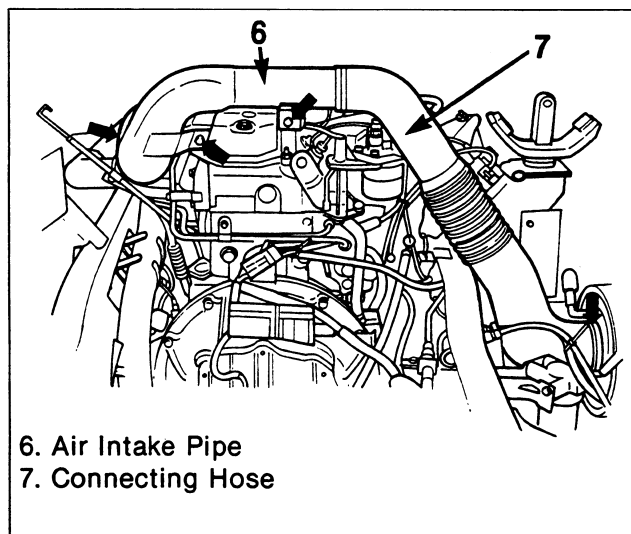
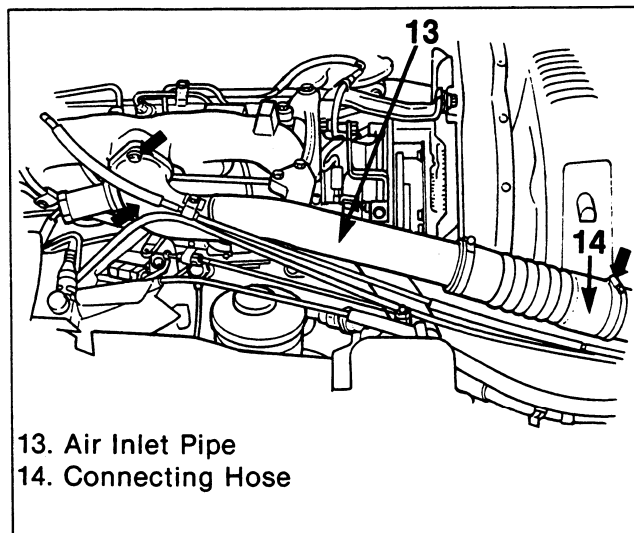

Figure 3. Air Intake Pipe to Turbocharger Attachment

7. Air inlet pipe (9) with connecting hoses (10) and (11) from the turbocharger (8) and charge air cooler (12) (figure 4).
8. Air inlet pipe (13) with connecting hose (14) from the intake manifold and the charge air cooler (12) (figure 5).
9. Charge air cooler assembly (12) from the radiator.
10. Automatic transmission cooler lines from

radiator and transmission (A/T only). Refer to AUTOMATIC TRANSMISSION (SEC. 7A).

11. Heater hoses from the water pump and the thermostat housing. Refer to COOLING SYSTEM (SEC. 6B1).
12. Fan and fan clutch from the fan clutch plate. Refer to FAN (SEC. 6B3).
13. Radiator hoses from the radiator. Radiator and shroud. Refer to RADIATOR (SEC. 6B2).
14. Air conditioning compressor, generator and water pump belts. Refer to AIR CONDITIONING (SEC. 1B), COOLING SYSTEM (SEC. 6B1) and ENGINE ELECTRICAL (SEC. 6D) in this manual.
15. Fuel lines at the frame near the injection pump. Refer to FUEL SYSTEM (SEC. 6C1).



13. Air Inlet Pipe
14. Connecting Hose

Figure 5. Intake Manifold Pipe Attachment

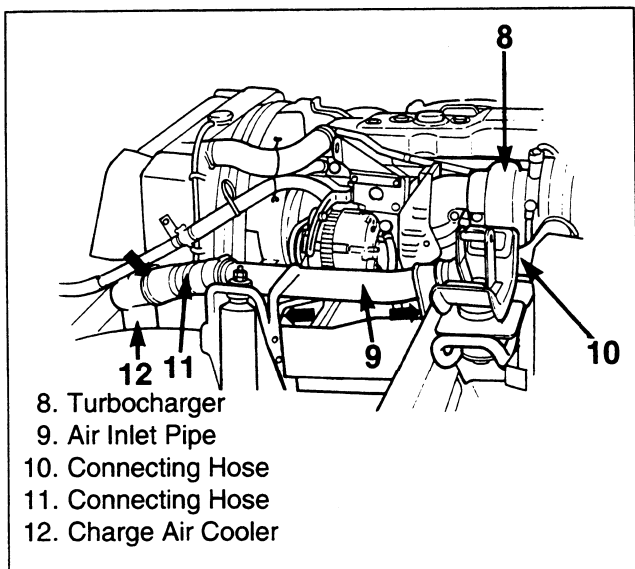

8. Turbocharger
9. Air Inlet Pipe
10. Connecting Hose
11. Connecting Hose
12. Charge Air Cooler

Figure 4. Air Intel Pipe Attachment

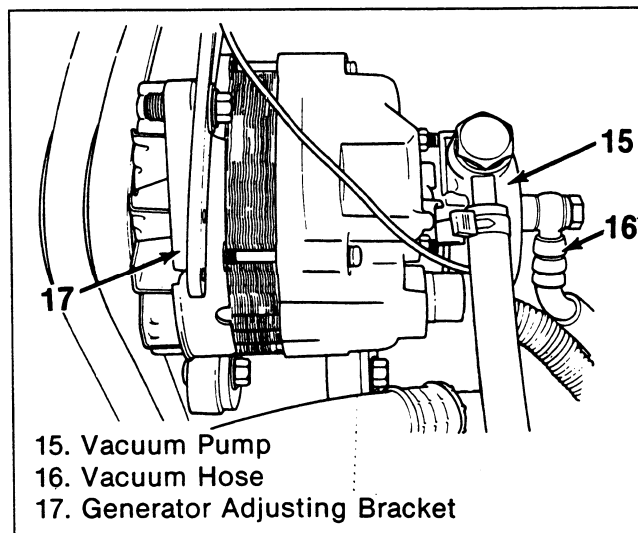

15. Vacuum Pump
16. Vacuum Hose
17. Generator Adjusting Bracket

Figure 6. Vacuum Hose Attachment at Vacuum Pump

16. Fuel shutoff cable at the injection pump and at the support bracket. Refer to DIESEL FUEL INJECTION (SEC. 6C3).
17. Electrical wires at the oil pressure and engine coolant temperature sending units. Refer to ENGINE ELECTRICAL (SEC. 6D).
18. Vacuum hoses (16) at the vacuum pump (15) (figure 6).
19. Generator output wire (19) from the generator (18) (figure 7).
20. Generator adjusting bracket (17) (figure 6).

21. Generator (18) and air conditioning compressor (20) as a unit. Do not remove the hoses from the compressor (figure 8).
22. Power steering hoses from the power steering pump. Refer to POWER STEERING (SEC. 3B3).

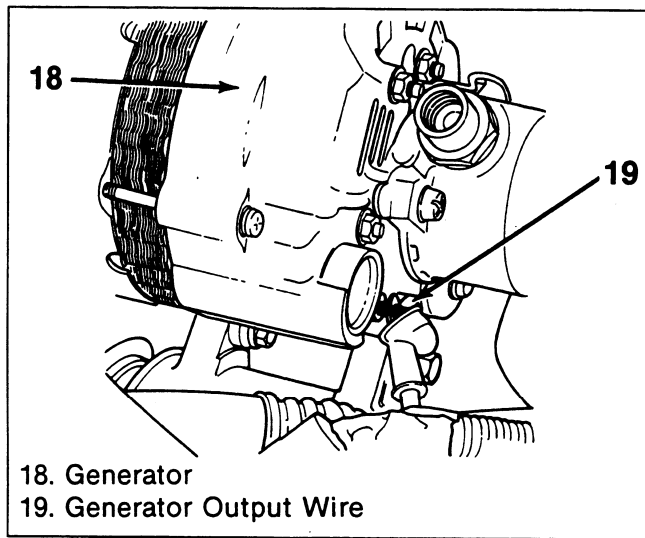

Figure 7. Wiring at Generator

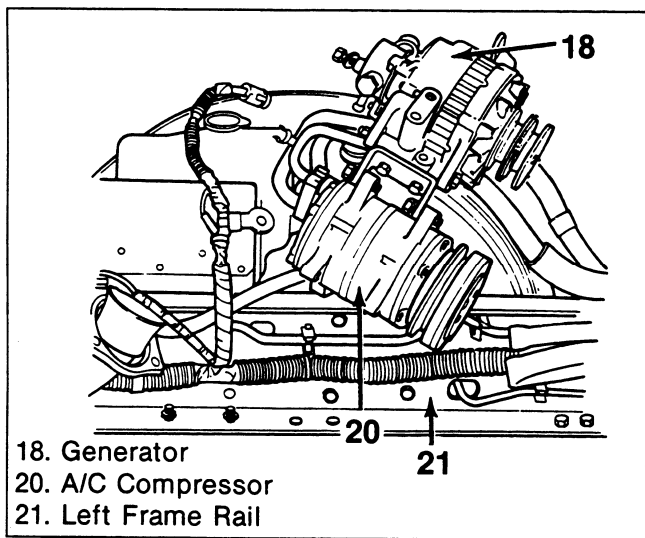

Figure 8. Generator and Air Conditioner (A/C) Compressor Removed

assembly (35) (figure 13).
 34. Engine by raising front, pulling forward, then turning the engine 90 degrees.

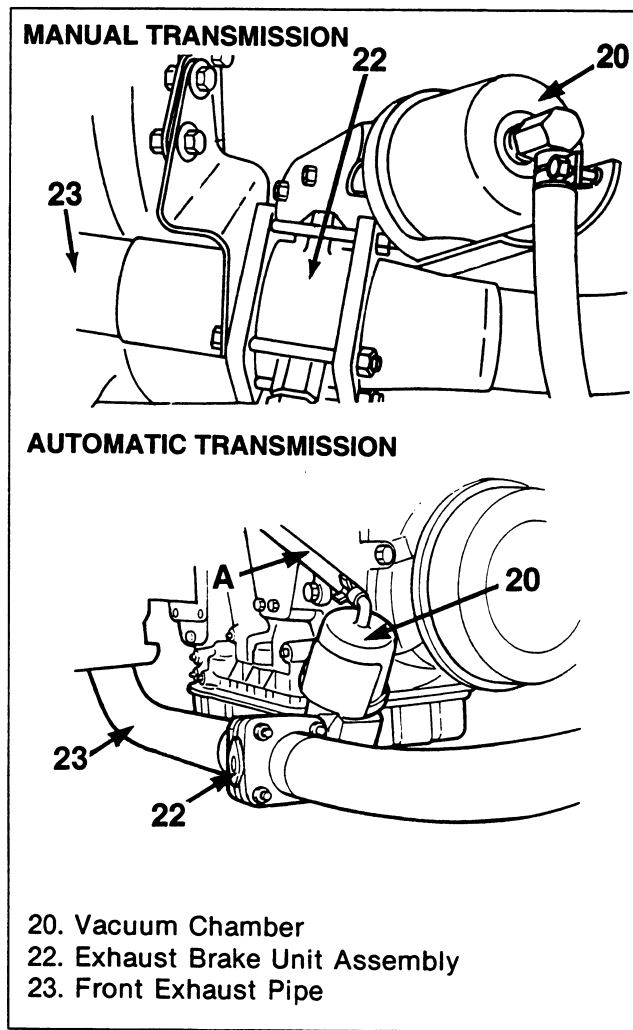

Figure 9. Exhaust Brake Installed

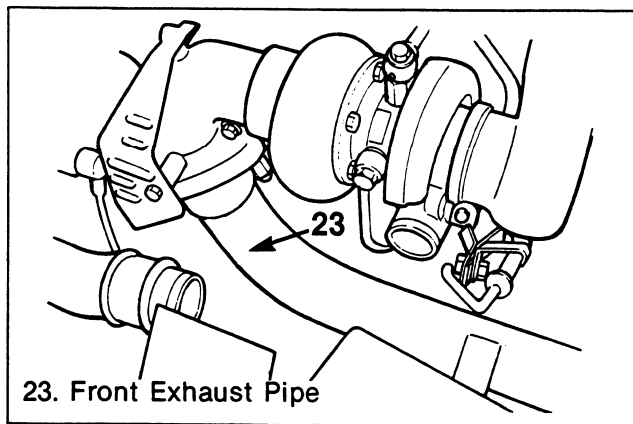
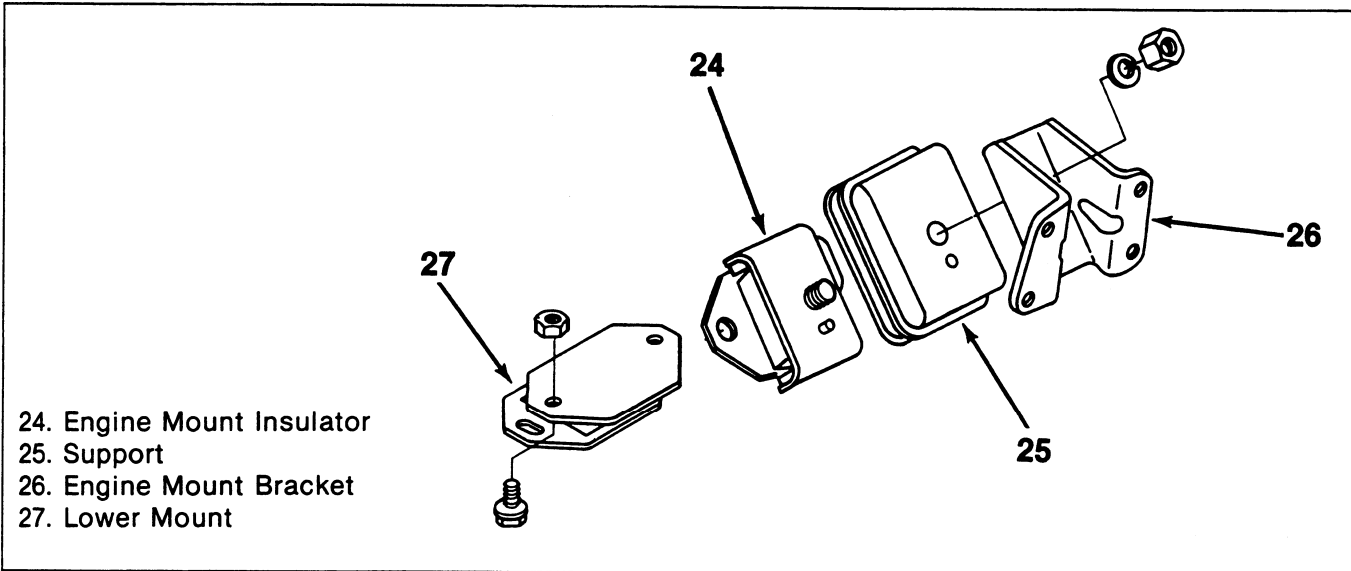

Figure 10. Exhaust Pipe Attachment

- 23. Shift and select cables from transmission. Refer to AUTOMATIC TRANSMISSION (SEC. 7A) or MANUAL TRANSMISSION (SEC. 7B).
- 24. Clutch slave cylinder. Refer to CLUTCH (SEC.7C).
- 25. Exhaust brake unit assembly (22) (figure 9).
- 26. Front exhaust pipe (23) (figure 10).
- 27. Electrical wiring harness and connectors.
- 28. Speedometer cable from transmission.
- 29. Propeller shaft and parking brake assembly. Refer to MANUAL TRANSMISSION (SEC. 7B).
- 30. Engine mount insulator (24) to engine mount bracket nuts (figure 11).
- 31. Transmission to frame crossmember side supports (30) (figure 12).
- 32. Raise the transmission with a jack and remove the clutch housing to transmission bolts.
- 33. Attach a sling (34) and hoist to the engine



- 24. Engine Mount Insulator
- 25. Support
- 26. Engine Mount Bracket
- 27. Lower Mount

Figure 11. Front Engine Mount

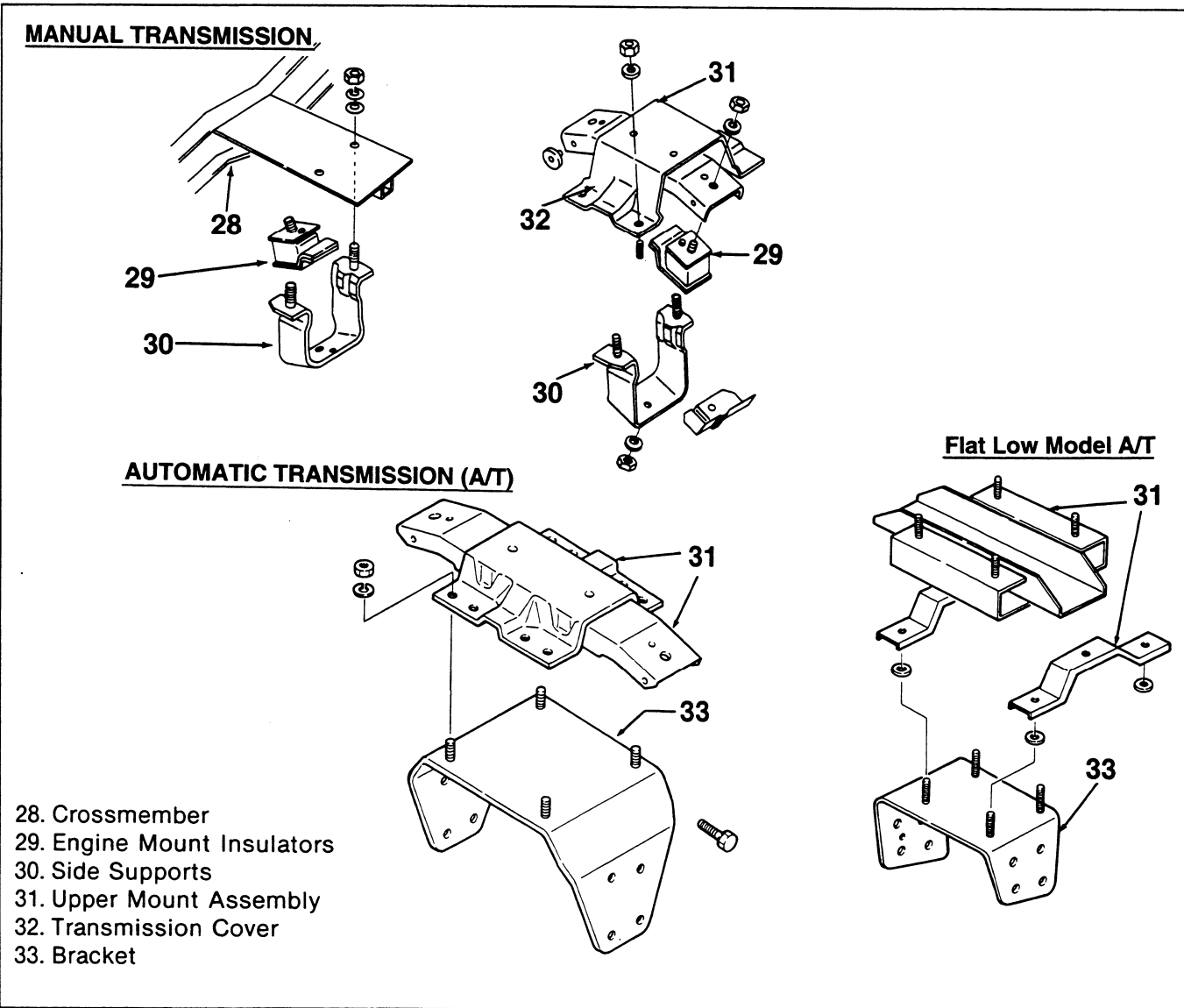

- 28. Crossmember
- 29. Engine Mount Insulators
- 30. Side Supports
- 31. Upper Mount Assembly
- 32. Transmission Cover
- 33. Bracket

Figure 12. Transmission Mount

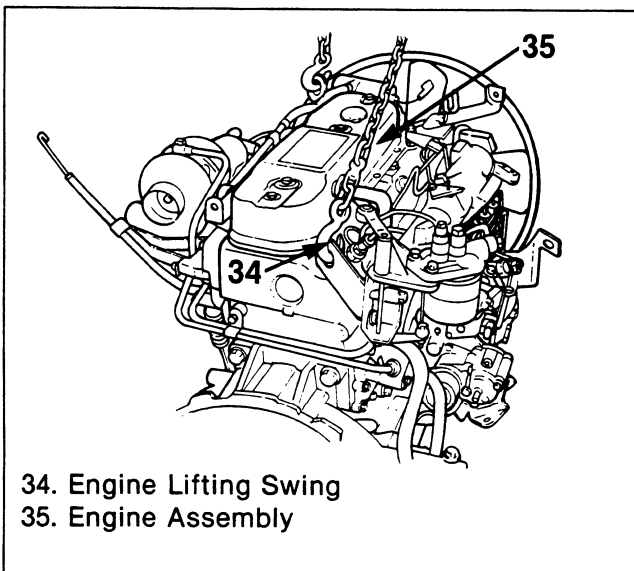

Figure 13. Lifting Sling on Engine

Install or Connect (Figures 1-13)

NOTICE: See "NOTICE" on page 6A-1 of this section for steps 7, 8, 9 and 10.

1. Clutch pressure plate assembly and clutch driven plate. Refer to CLUTCH (SEC. 7C).
2. Sling (34) and hoist to the engine (35) (figure 13).
3. Support and raise the transmission with a jack.
4. Position and align the engine and the transmission input shaft. Keep the flywheel housing and clutch housing parallel with one another.
5. Mate the flywheel and clutch housings. Fabricated pilot studs may help to maintain alignment while connecting the housing.
6. Flywheel to clutch housing bolts except the clutch slave cylinder, wiring harness bracket, and exhaust brake bracket bolts. Do not torque the bolts yet.
7. Engine mount insulator (29) to the engine mount bracket (31) (figure 11).
 - It may be necessary to loosen the engine mounts from the frame to align the stud to bracket holes.

Tighten

- The mount insulator nuts to 75 N·m (55 lb·ft).

8. Transmission mount.

Tighten

- The mount to transmission cover nuts to 69 N·m (51 lb·ft).

9. Position the clutch slave cylinder, the wiring harness bracket, and the exhaust brake bracket onto the flywheel to clutch flange. Then install the bolts.

Tighten

- Flywheel housing to clutch housing bolts to 81 N·m (60 lb·ft).

10. Shift and select cable bracket onto the clutch housing.

Tighten

- Bracket bolts to 81 N·m (60 lb·ft).

11. Parking brake assembly and propeller shaft. Refer to MANUAL TRANSMISSION (SEC. 7B).
12. Speedometer cable to the transmission.
13. Power steering hoses and brackets onto the power steering pump. Refer to POWER STEERING (SEC. 3B3).
14. Generator and air conditioning compressor onto the cylinder block.
15. Generator adjusting bracket (17) (figure 6).
16. Generator output wire (19) to the generator (18) (figure 7).
17. Vacuum hose (16) to the vacuum pump (15) (figure 6).
18. Electrical wiring harness and connectors.
19. Fuel shutoff cable onto the injection pump. Secure their support brackets. Refer to DIESEL FUEL INJECTION (SEC. 6C3).
20. Fuel lines at the vehicle frame near the injection pump. Refer to FUEL SYSTEM (SEC. 6C1).
21. Generator, water pump and air conditioning compressor belts. Refer to AIR CONDITIONING (SEC. 1B), COOLING SYSTEM (SEC. 6B1) and ENGINE ELECTRICAL (SEC. 6D).
22. Radiator, fan shroud and radiator hoses. Refer to RADIATOR (SEC. 6B2).
23. Fan clutch and fan to the fan clutch plate. Refer to FAN (SEC. 6B3).
24. Automatic transmission (A/T) cooler lines to the radiator and the transmission (A/T only). Refer to AUTOMATIC TRANSMISSION (SEC. 7A).
25. Front exhaust pipe (23) and exhaust brake unit assembly (22) (figures 9 and 10).
26. Charge air cooler assembly (12) to the radiator.
27. New gasket and the air inlet pipe (13) with connecting hose (14) (figure 5).
28. Air inlet pipe (9) with connecting hoses (10) and (11) to the charge air cooler (12) and turbocharger (8) (figure 4).
29. Air intake pipe (6) with connecting hose (7) (figure 3).
30. Heater hoses at the water pump and thermostat housing. Refer to COOLING SYSTEM (SEC. 6B1).

31. Be sure the oil pan plug is tight. Install 11.2 liters (3 gal) of engine oil. The SAE weight will depend on the ambient temperature. Refer to MAINTENANCE AND LUBRICATION (SEC. 0B).
32. Close the radiator drain valve. Fill the cooling system as described in COOLING SYSTEM (SEC. 6B1).
33. Connect the main feed wire (5) at the starter, and the battery negative cable (1), at the battery (figures 1 and 2).
34. Check the automatic transmission fluid level and replenish as necessary (Automatic transmission only). Refer to AUTOMATIC TRANSMISSION (SEC. 7A).

ENGINE MOUNTINGS

DESCRIPTION

Cushion-type mountings are used at both the front and rear of the engine on all vehicles covered in this manual. ("Front" refers to the end of engine opposite the flywheel.)

Engine mountings are illustrated in figures 11 and 12.

MAINTENANCE

Engine mountings should be inspected periodically and if found damaged or deteriorated they should be replaced.

Check the engine mount brackets for cracks or elongated bolt holes. Replace the brackets if necessary. Check the mounting fasteners for the correct torque. Inspect the rubber parts for deterioration and replace if necessary.

NOTICE: Broken or deteriorated mounts can cause misalignment and eventual destruction of certain drive train components. If a single mounting is misaligned, damaged, or broken, the remaining mountings are subjected to abnormally high stresses. This may cause breakage or damage to the remaining mountings.

FRONT ENGINE MOUNT REPLACEMENT

Remove or Disconnect (Figure 11)

NOTICE: When supporting the engine to replace a mount, raise the engine only to height required to provide clearance for mounting removal. Be careful that control linkage and wiring are not damaged from raising the engine. When replacing a single front mounting, both mountings should be detached before attempting to raise the engine. Failure to do this will place excessive stress on the attached mounting when the engine is raised.

NOTICE: When raising or supporting the engine for any reason, do not use a jack under the oil pan, any sheet metal or crankshaft pulley. Due to the small clearance between the oil pan and the oil pump screen, jacking against the oil pan may cause it to be damaged or bent against the pump screen, resulting in a damaged oil pickup unit.

1. Engine mount bracket (26) attached to cylinder block.
2. Nuts and bolts holding lower mount (27) to frame mount bracket.
3. Engine mount insulator (24) to engine mount bracket nut.
4. Frame bracket to frame nuts and bolts (if necessary.).
5. Engine mount insulator (24) to lower mount (27) nuts and bolts.

Install or Connect (Figure 11)

NOTICE: See "NOTICE" on page 6A-1 of this section for steps 2 and 5.

1. Lower mount (27) to the engine mount insulator (24).
2. Frame bracket to frame nuts and bolts (if removed).

Tighten

- Frame nuts and bolts to 38 N·m (28 lb·ft).
3. Engine mount bracket (26) to the cylinder block.
 4. Engine mount insulator (24) and the lower mount assembly (27) to the engine mount bracket (26) with the nut and washer.
 5. Lower mount (27) to the frame bracket nuts and bolts.

Tighten

- Frame bracket nuts and bolts to 38 N·m (28 lb·ft).

REAR ENGINE MOUNT REPLACEMENT

Remove or Disconnect (Figure 12)

NOTICE: When supporting the engine to replace a mount, raise the engine only to height required to provide clearance for mounting removal. Be careful that control linkage and wiring are not damaged from raising the engine. When replacing a single mounting, both mountings should be detached before attempting to raise the engine. Failure to do this will place excessive stress on the attached mounting when the engine is raised.

NOTICE: When raising or supporting the engine for any reason, do not use a jack under the oil pan, any sheet metal or crankshaft pulley. Due to the small clearance between the oil pan and the oil pump screen, jacking against the oil pan may cause it to be damaged or bent against the pump screen, resulting in a damaged oil pickup unit.

- Support the transmission with a transmission or jack. The transmission mount is also the rear engine mount.
 1. Side supports (30) to crossmember (28), nuts and washers.

2. Transmission cover (32) to upper mount (31) nuts, and washers.
3. Lower the transmission slightly and remove the mount assembly.
4. Nuts and washers and the insulators (29) from the upper mount (31).

Install or Connect (Figure 12)

NOTICE: See “NOTICE” on page 6A-1 of this section for steps 2 and 3.

- Support the transmission with a transmission or garage jack.
 1. Engine mount insulators (29) to the upper mount assembly (31).
 2. Upper mount assembly (31) onto the transmission cover (32).

Tighten

- Transmission cover nuts to 69 N·m (51 lb-ft).
3. Raise the transmission and install the side supports (30) onto the frame crossmember (28). Remove the jack.

Tighten

- Side support nuts to 41 N·m(30 lb-ft).

EXHAUST BRAKE SYSTEM

DESCRIPTION

The exhaust brake system, when turned on, increases the amount of power absorbed by the engine while coasting with the clutch engaged (figure 14).

The main components of the system are:

1. The exhaust brake valve (17). This valve resembles the manifold heat valve used in many gasoline engines.
2. The vacuum chamber (16).
3. The magnetic valve (13), which is an electric solenoid actuated valve.
4. The control switches (6, 10, 11 and 12).
5. The relays (5 and 9).

OPERATION

Exhaust Brake

Refer to figure 14.

1. When the engine starts, the generator turns the charge relay (3) on, which causes the exhaust brake relay (5) to go on via fuse No. 19.

2. When the exhaust brake switch (6) is turned on, electricity flows via the diode (8) to the exhaust brake control relay (9) and lights the indicator light (7) at the same time.
3. The exhaust brake control relay (9) goes on when the neutral switch (Manual transmission=M/T) or the inhibitor switch (Automatic transmission=A/T) (10) is off (when M/T is in a position other than neutral and A/T is in a position other than P or N).
4. When the exhaust brake control relay (9) goes on, a working current flows via the clutch switch (11) and the accelerator switch (12) to the magnetic valve (13).
5. Both the clutch switch (11) and accelerator switch (12) are normally closed. When both clutch and accelerator pedals are in the released position (engine at idle/clutch fully engaged), current flows to the magnetic valve (13).
6. When energized, the magnetic valve (13) opens, allowing vacuum to flow from vacuum pump (14) and tank (15) to the vacuum

chamber (16).

7. When supplied with a vacuum source, the vacuum chamber (16) pulls the exhaust brake valve (17) shut. With the engine brake valve shut, exhaust pressure allows the engine to become a more effective brake.
8. If the clutch or accelerator pedal depressed, the clutch switch (11) or accelerator switch (12) opens, or neutral/inhibitor switch (10) is ON, the exhaust brake control relay (9) opens, the power supply to the magnetic valve (13) is interrupted. The magnetic valve close, removing vacuum from the vacuum chamber (16). The vacuum chamber spring then pushes the exhaust brake valve (17) back open. Normal engine operation resumes.

The exhaust brake valve is also used to warm up the engine.

Automatic Engine Warm-up

When the engine coolant temperature is below 40°C (104°F) when the engine is started, a working current is supplied by the QOSIII controller to the upstream of the accelerator switch (12). But all

other conditions than the accelerator switch (12) remain unchanged. Therefore, the magnetic valve (13) is turned on and activates the exhaust brake valve (17) to promote the engine warm-up.

When the engine coolant temperature rises above the 40°C (104°F) level, the QOSIII controller automatically deactivates the engine warm-up function.

Manual Engine Warm-up

When the engine warming-up switch (19) goes on with the engine coolant temperature below 70°C (158°F) and the key switch (18) turned on, the indicator light built into the switch lights up and the engine warming cut relay (20) goes on at the same time. This causes electricity to flow to the magnetic valve (13) and activates the exhaust brake valve (17) to promote the engine warm-up.

When the engine coolant temperature rises above the 70°C (158°F) level, the thermo switch (21) and the engine warming cut relay (20) go off simultaneously. The engine warm-up function is ended as a result.

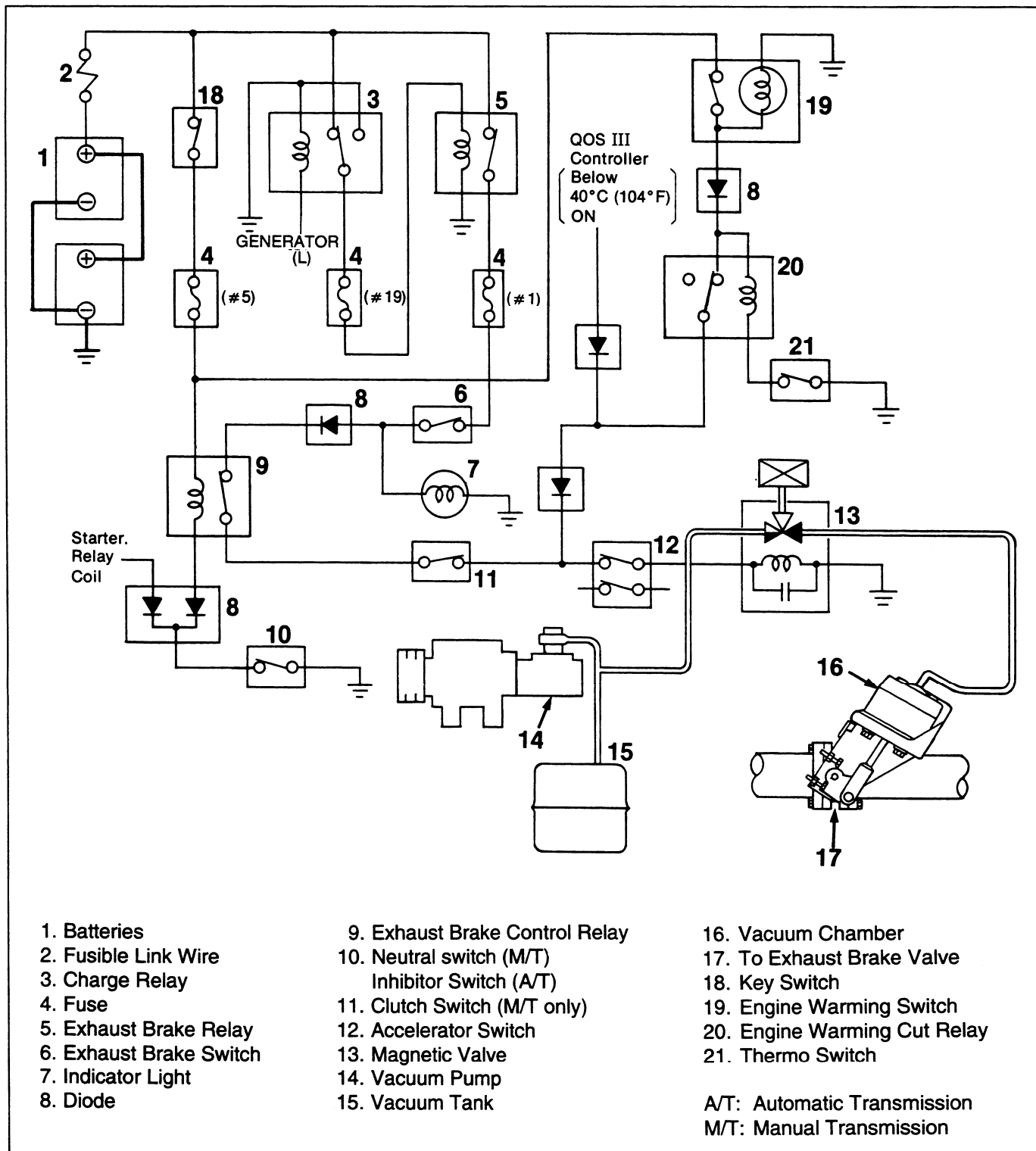

- | | | |
|-------------------------|--------------------------------|------------------------------|
| 1. Batteries | 9. Exhaust Brake Control Relay | 16. Vacuum Chamber |
| 2. Fusible Link Wire | 10. Neutral switch (M/T) | 17. To Exhaust Brake Valve |
| 3. Charge Relay | Inhibitor Switch (A/T) | 18. Key Switch |
| 4. Fuse | 11. Clutch Switch (M/T only) | 19. Engine Warming Switch |
| 5. Exhaust Brake Relay | 12. Accelerator Switch | 20. Engine Warming Cut Relay |
| 6. Exhaust Brake Switch | 13. Magnetic Valve | 21. Thermo Switch |
| 7. Indicator Light | 14. Vacuum Pump | |
| 8. Diode | 15. Vacuum Tank | |
- A/T: Automatic Transmission
M/T: Manual Transmission

Figure 14. Exhaust Brake and Engine Warm-up Controls

DIAGNOSIS OF EXHAUST BRAKE

PROBLEM	POSSIBLE CAUSE	CORRECTION
Exhaust Brake does not Operate	<ol style="list-style-type: none"> 1. Blown fuse. 2. Improperly adjusted or faulty accelerator or clutch switches. 3. Poor connections or corroded terminals at switches or control valve. 4. Improperly adjusted or seized exhaust brake valve. 5. Vacuum lines kinked, restricted, or plugged with ice. 6. Seized vacuum chamber. 7. Valve linkage broken. 8. Chamber or control valve jammed with ice. 9. Faulty control valve. Valve should open when 12 volts is applied to terminals. 10. Faulty vacuum chamber. 11. Broken wire in wiring harness. 	<ol style="list-style-type: none"> 1. Replce. 2. Adjust or replace. 3. Clean or replace. 4. Adjust, or repair. 5. Repair. 6. Repair. 7. Repair 8. Melt ice, Darin lines of water. 9. Replace. 10. Replace. 11. Repair.
Exhaust Brake Slow to Operate	<ol style="list-style-type: none"> 1. Tighten exhaust brake valve or linkage. 2. Improperly adjusted accelerator or clutch switches. 	<ol style="list-style-type: none"> 1. Free up and lubricate. 2. Adjust.
Weak Braking Action	<ol style="list-style-type: none"> 1. Improperly adjusted or tight exhaust brake valve. 2. Tight linkage. 3. Vacuum lines kinked or partially plugged with ice. 4. Leaking fittings at vacuum lines. 5. Leaky vacuum chamber. 	<ol style="list-style-type: none"> 1. Free up and/or adjust. Lubricate as needed. 2. Free up and lubricate. 3. Repair. 4. Tighten. 5. Replace.
Exhaust Brake will not Shut Off (Exhaust Brake Control Switch "Off")	<ol style="list-style-type: none"> 1. Seized exhaust brake valve or linkage. 2. Control valve or chamber jammed with ice. 3. Short in wiring harness (12 volts at control solenoid regardless of control switch position). 4. Faulty control switch. 	<ol style="list-style-type: none"> 1. Free up and lubricate. 2. Melt ice and drain lines. 3. Repair. 4. Replace.
Exhaust Brake "On" Continuously when Exhaust Brake Control Switch is "On" (not Controlled by Clutch or Accelerator Switches)	<ol style="list-style-type: none"> 1. Improperly adjusted clutch or accelerator switches. 2. Switches improperly wired. 3. Short in wiring harness. 	<ol style="list-style-type: none"> 1. Adjust. 2. Check wiring against wiring diagram. Repair as needed. 3. Repair.
Engine Overheats or Loses Power	<ol style="list-style-type: none"> 1. Engine brake valve stuck partially closed. 2. Engine brake valve adjusted so that it is partially closed. 	<ol style="list-style-type: none"> 1. Free up and lubricate or replace. 2. Adjust.

EXHAUST BRAKE ON-VEHICLE SERVICE

COMPONENT LOCATIONS

Refer to figures 15, 16, 17, 18 and 19.

- The exhaust brake valve (11), vacuum chamber (10) and related components are located at the left rear of the engine (figure 15).
- The magnetic control valve (9) is located inside the left frame rail, rear of the battery box (88) (figure 16).
- The accelerator switch (5) is located on a bracket above the accelerator pedal (99) (figure 17).
- The clutch switch (7) is located above the clutch pedal (62) (figure 18).

For wire color information, refer to WIRING DIAGRAMS (SEC. 8F) in this manual.

MAGNETIC VALVE REPLACEMENT

Remove or Disconnect (Figure 19)

1. Magnetic valve wires (113).
2. Vacuum lines (114).
3. Bolts, nuts and washers.
4. Magnetic valve (9).

Install or Connect (Figure 19)

1. Magnetic valve (9) to frame rail (116).
2. Bolts, washers and nuts.
3. Vacuum lines (114).
4. Magnetic valve wires (113).

VACUUM CHAMBER REPLACEMENT

This procedure is described under "Exhaust Brake Valve Replacement".

EXHAUST BRAKE VALVE REPLACEMENT

Remove or Disconnect (Figures 9, 10 and 15)

1. Separate front exhaust pipe (21) from rear exhaust pipe (53). Refer to EXHAUST (SEC. 6F).
2. Vacuum hose (A) from vacuum chamber (20).
3. Exhaust brake valve and vacuum chamber assembly.
4. Cotter pin, clevis pin and vacuum chamber from valve assembly.
5. Valve assembly from bracket. Replace the valve assembly as a unit only.

Inspect

- If the exhaust brake valve exhibits wear or damage, it must be replaced as a unit.
- Apply penetrating oil to the valve shaft and bushings if the shaft appears sticky.

Important

- Do not disturb the setting of the stop bolt. It is factory preadjusted.

MANUAL TRANSMISSION

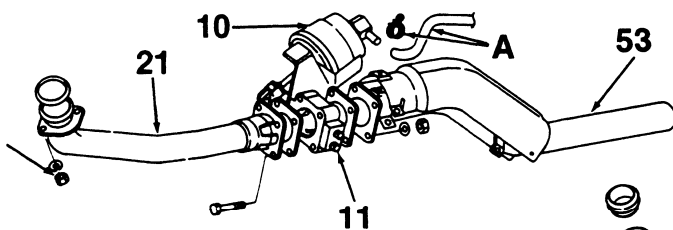

10. Vacuum Chamber
11. Exhaust Brake Valve
21. Front Exhaust Pipe
52. Manifold to Outlet Pipe Nut
53. Rear Exhaust Pipe
- A. Vacuum Hose and Clamp

AUTOMATIC TRANSMISSION

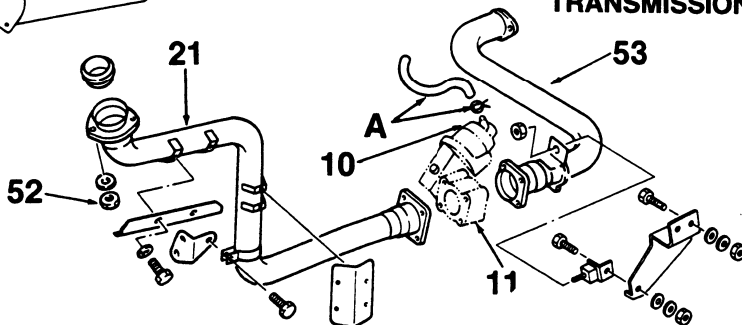

Figure 15. Engine Brake Valve

Install or Connect (Figures 9, 10 and 15)

1. Nuts, clevis and pin to connect vacuum chamber to exhaust brake valve assembly.
2. Exhaust brake unit assembly using new gaskets between the exhaust pipes (figure 9).

Tighten

- Exhaust nuts to 17 N·m (12 lb·ft).
3. Vacuum hose and clamp to the vacuum chamber (20). Overlap the hose on the fitting 30 mm (1.2 in) (figure 9).

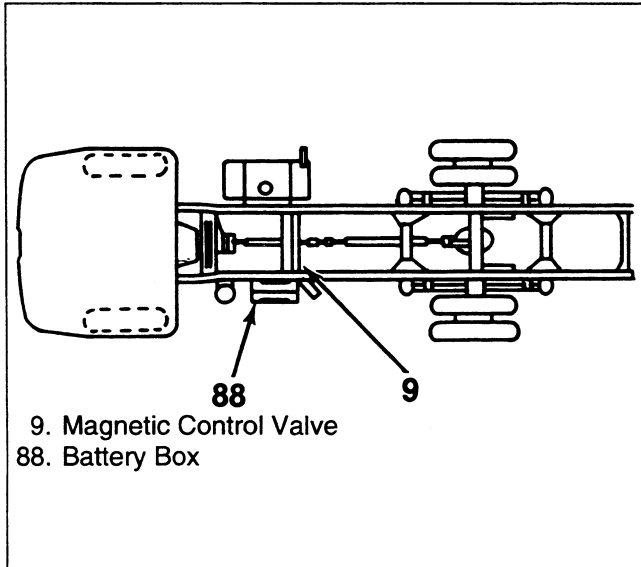

Figure 16. Exhaust Brake Control Valve Location

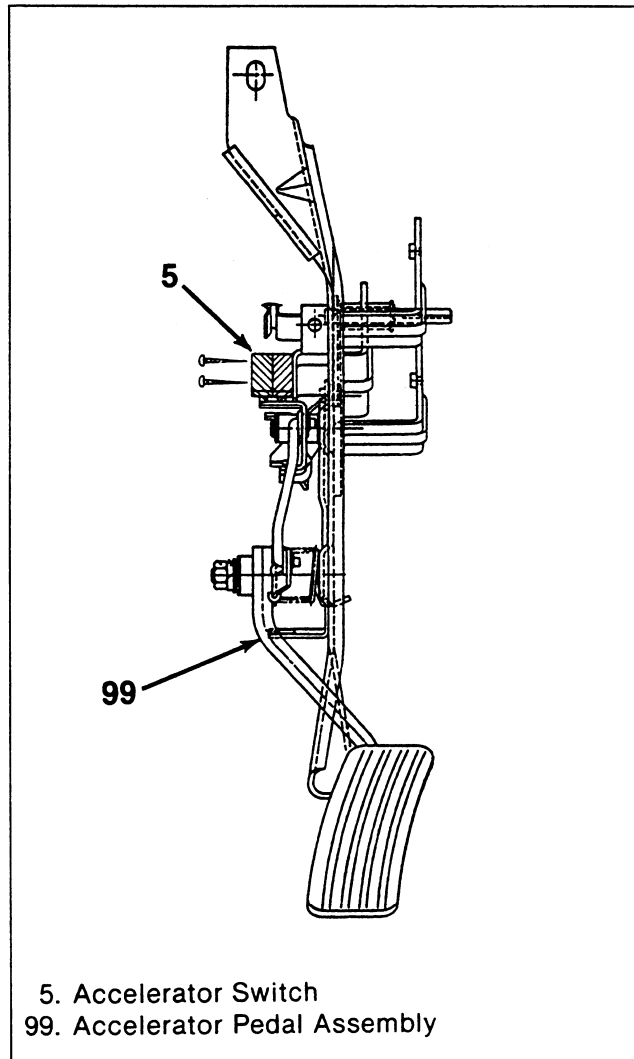

Figure 17. Accelerator Switch

ACCELERATOR SWITCH REPLACEMENT

Remove or Disconnect (Figures 17 and 20)

1. Battery negative cable.
2. Connector at accelerator switch (5).
3. Screw.
4. Accelerator switch (5).

Install or Connect (Figures 17 and 20)

To install follow the removal step in reverse order.

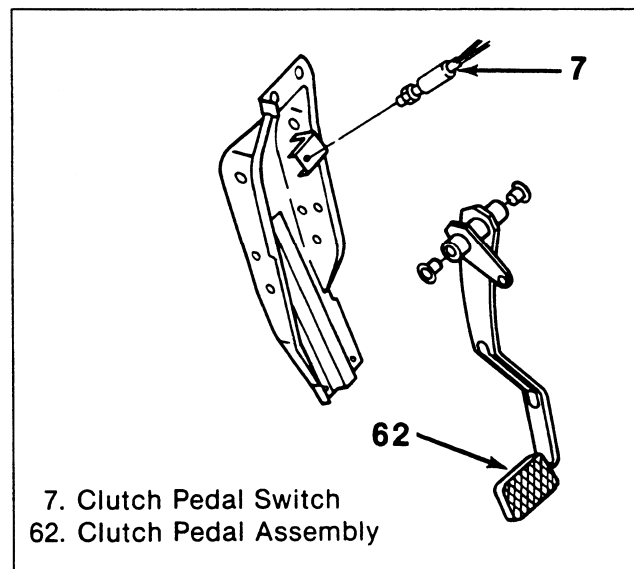

Figure 18. Clutch Pedal Switch

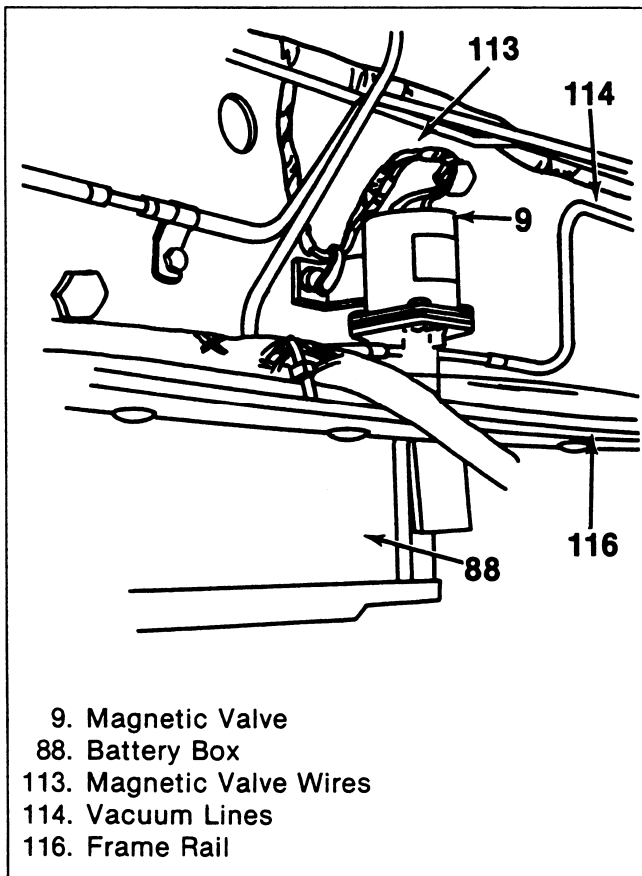

Figure 19. Exhaust Brake Control Valve

CLUTCH SWITCH REPLACEMENT

Remove or Disconnect (Figures 18 and 20)

1. Battery negative cable.
2. Switch wires.
3. Front switch nut (201) (figure 20).
4. Clutch switch (7) (figure 18).

Install or Connect (Figures 18 and 20)

1. Rear switch nut (211) on clutch switch (figure 20).
2. Clutch switch to bracket.
3. Front switch nut (201). Do not tighten.

Adjust

The clutch switch must be adjusted so that when the clutch pedal is released, it closes the switch but does not completely depress the switch plunger. If the plunger is completely depressed by the pedal, switch damage may result.

- Fully depress the switch plunger.
- Adjust the switch in its bracket until 0.5 to 1 mm (0.02 to 0.04 in) clearance exists between the fully depressed switch plunger and the contact area on the clutch lever (dimension 19) (figure 20).
- The switch should exhibit an open circuit (no continuity) when the accelerator pedal is depressed approximately 0.75 mm (0.03 in). The test may be made with a test light or an ohmmeter connected to the switch plug connector.

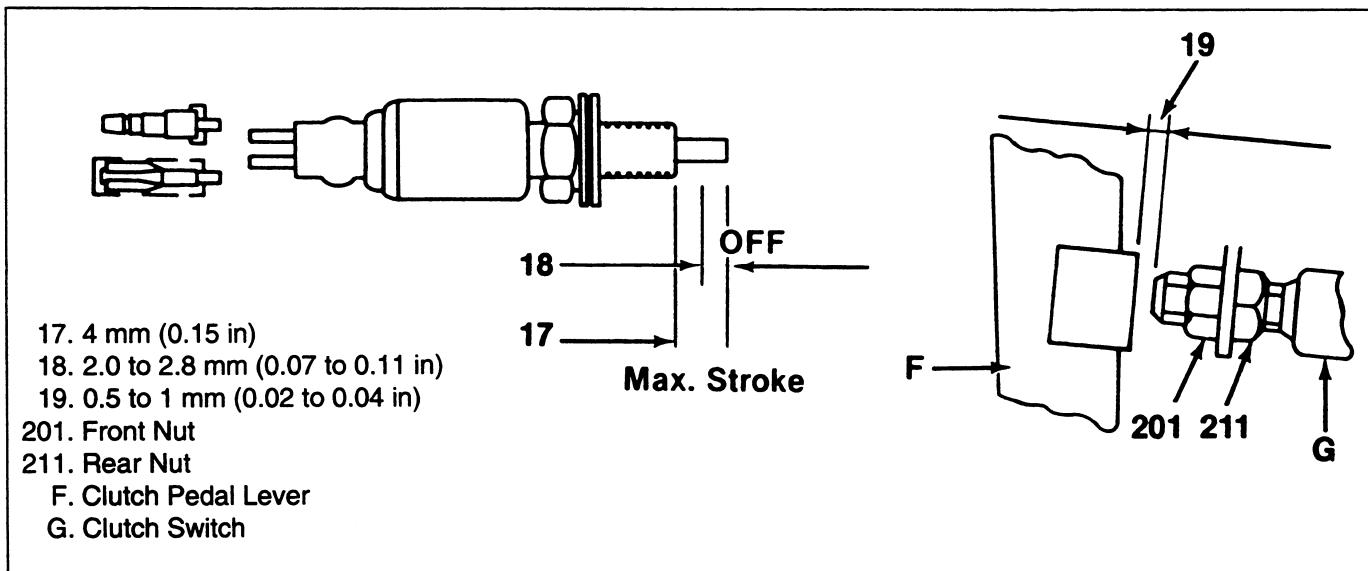

Figure 20. Servicing Clutch Switch

**Tighten**

- The switch nuts to 18 N·m (13 lb·ft).
Connect the switch wires.

4. Wires at the clutch switch.
5. Battery negative cable.

SPECIFICATIONS

FASTENER TORQUES

Front Engine Mount Bracket to Engine Bolts and Nuts	41 N·m (30 lb·ft)
Front Engine Mount to Frame Nuts and Bolts	38 N·m (28 lb·ft)
Front Engine Mount to Engine Bracket Nut	75 N·m (55 lb·ft)
Rear Engine Mount to Transmission Nuts	69 N·m (51 lb·ft)
Flywheel Housing to Clutch Housing Bolts	81 N·m (60 lb·ft)
Side Support Nuts	41 N·m (30 lb·ft)
Exhaust Brake to Exhaust Pipes Nuts	17 N·m (12 lb·ft)
Clutch Switch Nut	18 N·m (13 lb·ft)