



Installation Instructions #214

© 2005 KwikEE Document release date 02/05 Document #1421480

IMGL* and 9510 Control Replacement Kits *Integrated Motor/Gear Box/Linkage



Before attempting any electric step assembly repair work, please read all of the following instructions.

Disconnect the power at the vehicle battery once the step is extended.

Refer to the Electric Step Replacement Part Schematic, Figure 1, for item numbers referenced in these instructions.

IMGL (Integrated Motor/Gear Box/Linkage) Assembly

Instructions for removing and replacing the IMGL Assembly.

1. On Van Steps, remove plastic splash cover if so equipped. If the step is locked in the retracted (up) position where the plastic cover cannot be removed, the step tread will have to be disassembled to access the plastic cover. To disassemble the tread, remove the (8) 1/4-20 x 1" long hex head bolts in the tread side rails connecting the tread and the sliding blocks to the side rail. This will allow the tread to be dropped out of the way to access the plastic cover. Reassemble the tread after removing the cover.
2. To remove the IMGL assembly from the step it is easiest if the step is partially or fully extended. If possible extend the step with the standard door switch operation.

NOTE: See drawings on Page 2 and 3 for item numbers specified in the following steps.

3. **Steps using a control Unit:** Unplug the 4-way connector to the control unit (Item #6). Disconnect the wiring between the motor and the control unit (Item 7).

Steps without a control Unit: Cut the wires at the butt connectors approximately 12 " from the motor.

4. Remove the cotter pin from the clevis pin at the linkage assembly.
5. Remove the clevis pin (Item #2) from the cast "U" block in the end of the linkage assembly (Items #3, #4, or #5). Note the direction the clevis pin goes into the cast block. If the step is in its locked position, the pin may have to be pried or driven out of the block. The step tread(s) should now swing freely, if not check for a bent step frame or jammed pivot point(s).

6. Unbolt the motor assembly from the step frame.
7. Install new IMGL assembly on step frame and tighten all mounting bolts.
8. Install the clevis pin (Item #2) through the drive arms attached to the step frame and the cast block in the linkage assembly (Items #3, #4 or #5). Be sure to reinstall the clevis pin in the same direction it was removed. Install the cotter pin in the clevis pin.
9. Reconnect the wiring:
 - A. Wiring to a 909510000 Control Unit** - Plug the motor connector from the Control Unit into the motor.

B. Wiring to toggle switch only- Using the motor adapter pigtail connect the mating connector to the connector on the motor. Connect the red and yellow pigtail wires to the vehicle switch wires using heat shrink insulated butt connectors.

Plug in the 4-way connector between the control unit and the vehicle.

NOTE: On 23 and 34 Series steps, see the mounting instruction, Figure 3 and 4, when replacing a #8287 double reduction motor with a permanent magnet motor assembly.

IMGL and Control Unit Replacement Kits

| Part # | Linkage | For Step Series |
|-----------|---------|--|
| 909770000 | 'A' | 22, 23, 30, 32, 33, 34, 35, 36, 38, 40 |
| 909772000 | 'B' | 28, 31, 37, 39 |
| 909774000 | 'C' | 26 |

Replacement Kits contain an IMGL (integrated motor/gear box/linkage assembly, a Control Unit, four-way pigtail, and fastener kit.

Replacing the motor, gear box, and linkage with the IMGL on a step that has **any control other than a 909510000 Control Unit** (as included) requires the installation of the 909510000 Control included in the Replacement Kit.

Note: Any control unit or motor repair needed on steps using a Delco Field wound motor (part number 8002,8279,8278,8287) requires the IMGL and Control Unit included in the Replacement Kit.

Table of Contents

| | |
|----------------------------------|---|
| IMGL Replacement | 1 |
| Control Unit Replacement | 2 |
| Series 23 & 24 Motor Replacement | 4 |

CONTROL UNIT

Instructions for removing and replacing the control unit.

! Control unit #909510000 requires a normally open switch. If you are replacing a #9513, #9516, #9590 control unit you *MUST* also replace the door switch. The new control will *not* work with older, normally closed switches.

Proceed to the following steps after completing IMGL Assembly Removal steps 1-3.

1. **Controls prior to the 4-way Packard style connector** - Cut the molded rubber 4-way connector pigtail off just above the vehicle half of the butt connectors. Since all manufacturers use different colored wires for vehicle wiring, take a moment to note what color wires from the vehicle are connected to the white, red, brown and yellow wires of the pigtail. Strip the vehicle wires back and connect the new Packard style pigtail connector to the vehicle wiring using heat shrink insulated butt connectors. Make sure that the vehicle wires that were connected to the old pigtail are reattached to the new pigtail in the identical way.

NOTE: Van steps using door switch only operation will have two wires coming from the vehicle. Cut the wires just above the connector and butt connect the pigtail wires to the vehicle wiring. Make sure that the vehicle wires that were connected to the old pigtail are connected to the new pigtail in the identical way.

2. Disconnect the black wire leading from the control unit to the understep light at the connector. Do not cut this wire.

NOTE: Not all steps are equipped with an understep light.

3. On steps with a blue, red, green, yellow, brown, or orange control unit, remove the screw securing the green wire from the control unit to the step frame. Save the screw for securing the green wire on the new control unit. On orange control units manufactured after 1991 remove the screw securing the 31" long 10 ga. green ground wire from the control unit to the vehicle chassis.

IMGL Assembly Drawing and Parts Key Numbers

FIGURE 1

| Item Number | Description |
|-------------|---------------------------|
| 1 | Motor and screws |
| 2 | Cotter and clevis pins |
| 3 | Gear box with linkage 'A' |
| 4 | Gear box with linkage 'B' |
| 5 | Gear box with linkage 'C' |

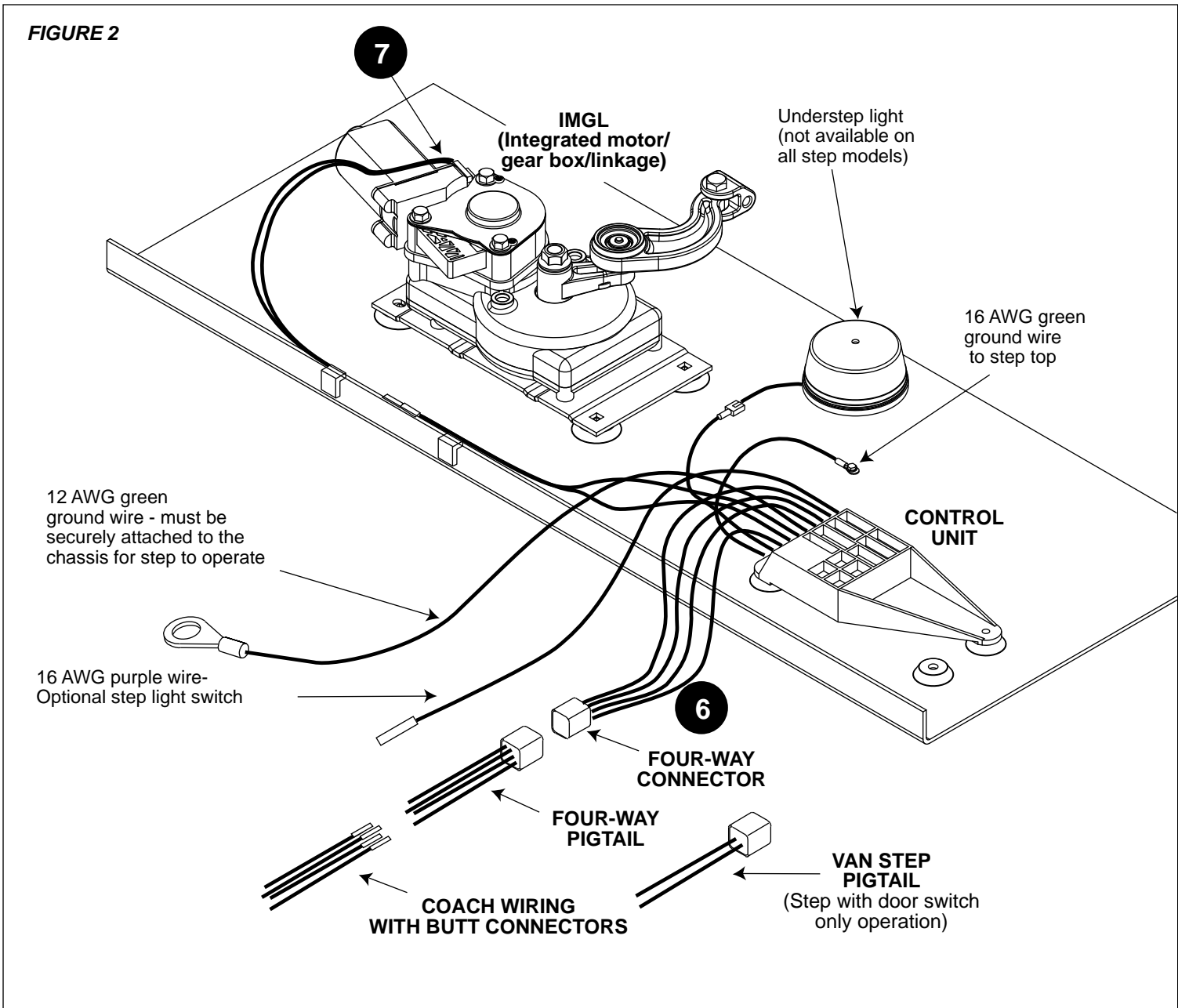

4. Remove the old control unit from the step frame. Save the mounting screws for mounting the new control unit to the step frame.
5. Using the screws saved from the old control, mount the new control to the step frame.
6. Reconnect the wiring:
 - A. Ground the 16 ga. green wire from the control unit to the step frame. Remove any corrosion at the attachment point. Attach it placing the external tooth lock washer supplied with the new control unit between the ring terminal on the end of the green wire and the step frame.

- B. Attach the 31" long 12 ga. green wire to the vehicle chassis. Scrape the connection point clear for a good ground connection. On steps with a braided ground cable, the braided cable may be removed.
- C. Connect the black wire from the control unit to the understep light. On steps not equipped with an understep light, wrap the black wire to protect it from the weather and secure it to keep it from dangling.
- D. Connect the connector to the step motor.

NOTE: The 909510000 Control Unit is to be used only with the AM Equipment 214 motor. The 214 number will be on a sticker on the motor.

7. Reinstall the Splash cover if the step was so equipped.
8. Reconnect the vehicle battery.
9. Test the step functions.

23 and 34 Series Step Motor Replacement

The four-way connector should be disconnected and the old gearbox assembly should already be removed from the step top as previously described.

1. If the step frame is mounted flush against the step mounting surface, the step will have to be removed to access the top side of the step frame.
2. The hole pattern for the new IMGL assembly does not line up properly with the old mounting holes. See **Figure 3** for a mounting diagram for the 23 Series Step and **Figure 4** for the 34 Series Step.

NOTE: All four mounting bolts must be used to attach the motor assembly to the step frame or the step may not operate properly and damage to the step may occur.

3. Bolt down the motor assembly and install the clevis pin and cotter pin as described in IMGL Assembly replacement step #8 on Page 1.
4. Remount the step to the vehicle.

NOTE: If you are installing a control unit, it will be easier to do this while the step is removed from the vehicle.

See **Figure 4** for important information on remounting 34 Series steps flush against the step mounting surface.

NOTE A: If the step is mounted flush against the mounting surface, the step must be removed from the vehicle before drilling the 9/32" dia. hole for attaching the motor assembly.

NOTE B: The 1/4" flat washers are used to shim the permanent magnet motor assembly away from the step top so the motor assembly will sit level. This is important for proper step operation.

NOTE C: If the step was originally installed flush against the step well, a 1/4" thick shim may be needed (not provided) so the motor assembly mounting bolt heads will clear the mounting surface.

FIGURE 3: 23 Series Step

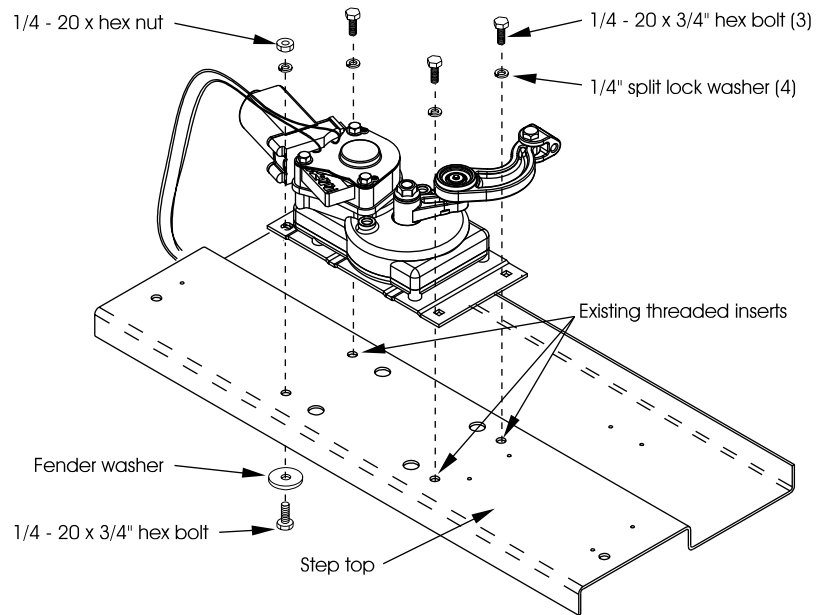

FIGURE 4: 34 Series Step

